



MASTERColour CDM-Tm Elite Mini



MASTERColour CDM-Tm Elite Mini 35W/930 GU6.5 1CT

Mini, single-ended, very high-efficiency, long-life Ceramic Metal Halide discharge lamp producing crisp white sparkling light with high colour rendering

Warnings and Safety

- Use only in totally enclosed luminaire, even during testing (IEC61167, IEC 62035, IEC60598)
- The luminaire must be able to contain hot lamp parts if the lamp ruptures
- Use only with electronic control gear
- For 50W use with Philips electronic gear only
- Control gear must include end-of-life protection (IEC61167, IEC 62035)

Product data

General information	
Cap base	GU6.5 [GU6.5]
Operating position	UNIVERSAL [Any/Universal]
Life to 5% failures (nom.)	12000 h
Life to 10% failures (nom.)	14000 h
Life to 20% failures (nom.)	16000 h
Life to 50% failures (nom.)	20000 h
ANSI code HID	C130/E
	Sphere

Light technical	
Colour Code	930 [CCT of 3,000 K]
Luminous flux (rated) (min.)	3600 lm
Luminous flux (rated) (nom.)	4000 lm

Colour designation	Warm white (WW)
Lumen maintenance 1,000 hours (nom.)	95 %
Lumen maintenance 12,000 hours (nom.)	80 %
Lumen maintenance 2,000 hours (nom.)	93 %
Lumen maintenance 4,000 hours (nom.)	90 %
Chromaticity coordinate X (nom.)	0.434
Chromaticity coordinate Y (nom.)	0.398
Correlated Colour Temperature (Nom)	3000 K
Luminous efficacy (rated) (nom.)	3950 lm/W
Colour-rendering index (min.)	87
Colour rendering index (nom.)	90

Operating and electrical	
Power (Rated) (Nom)	39.1 W

MASTERCLOUR CDM-Tm Elite Mini

Lamp current run-up (max.)	1 A
Re-ignition time (min.) (max.)	15 min
Ignition time (max.)	30 s
Voltage (Max)	95 V
Voltage (Min)	79 V
Voltage (Nom)	87 V

Controls and dimming

Dimmable	No
Run-up time 90% (max.)	3 min

Mechanical and housing

Lamp Finish	Clear
Bulb shape	T13.3

Approval and application

Energy Efficiency Class	F
Mercury (Hg) content (max.)	4.7 mg
Mercury (Hg) content (nom.)	4.7 mg
Energy consumption kWh/1,000 hours	40 kWh
	473261

UV

PET (NIOSH) (min.)	8 h/500lx
--------------------	-----------

Damage factor D/fc (max.)	0.4
---------------------------	-----

Luminaire design requirements

Bulb temperature (max.)	450 °C
Cap-base temperature (max.)	250 °C
Cap-Base Temperature (Max)-DUP(do not use)	482 °F

Product data

Full product code	871829115382500
Order product name	MASTERCLOUR CDM-Tm Elite Mini 35W/930 GU6.5 1CT
EAN/UPC – product	8718291153825
Order code	15382500
Local order code	CDMTM35930GU651
SAP numerator – quantity per pack	1
Local code description	LAMPADA HALETO METALICO CDMTM-EL35W930
Numerator – packs per outer box	12
SAP material	928187405130
Net Weight (Piece)	0.008 kg
ILCOS code	MT/UB-35/930-H-GU6.5-13.3/52

Dimensional drawing

D

Product	D (max)	D	O	L (min)	L (max)	L	C (max)
MASTERCLOUR CDM-Tm Elite Mini 35W/930 GU6.5 1CT	13.3 mm	0.5 in	4.7 mm	28 mm	32 mm	30 mm	56.7 mm

MASTERCLOUR CDM-Tm Elite Mini 35W/930 GU6.5 1CT

MASTERCoulour CDM-Tm Elite Mini

Photometric data

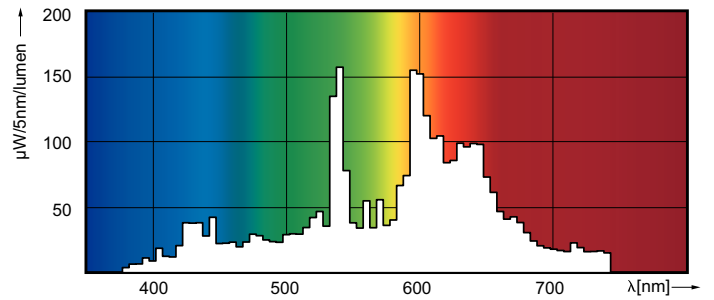
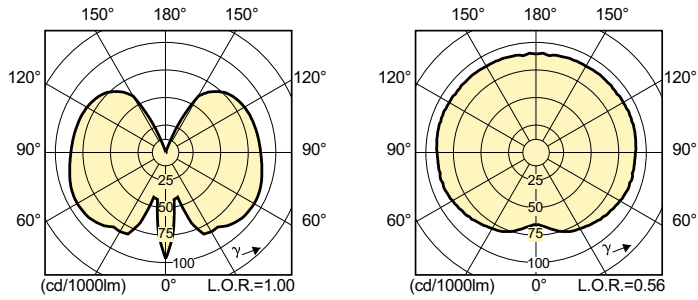

LDPO_CDM-Tm_35W_930_GU65-Spectral power distribution Colour

Lifetime

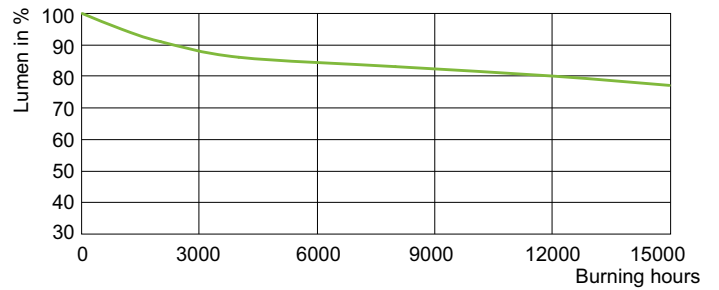
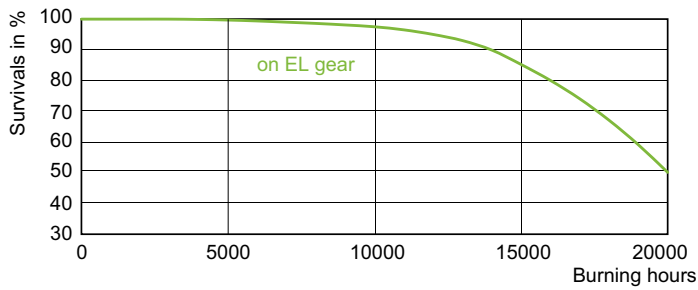

LDLM_CDM-Tm_0001-Lumen maintenance diagram

