

EASI6001

EASITRADE 12W 4000K IP20 Slimline Downlight

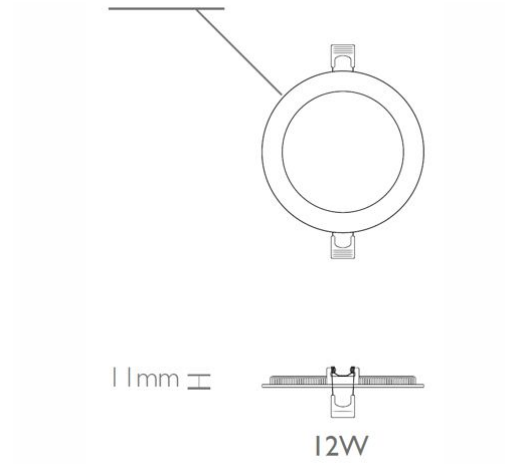
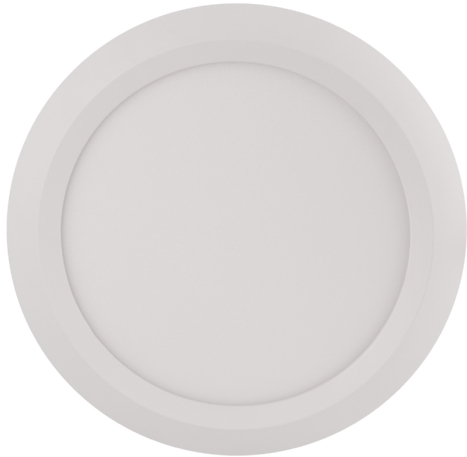

General Details

Finish	Matte White Finish
Product Weight	0.65KG
Overall Dimensions	ø165mm x 11mm / Cut Out ø145
Carton Weight / Material	0.90 kg / Cardboard
Packaging Sizes / Packed Weight	Length 180mm, Height 90mm, Width 180mm
Packaging & Labelling Guidelines	Saturn LED.eu - Generic labelling
Bar Coding	Saturn LED coding in accordance with EAN-12 & ITF-14
IP Rating	IP20
Energy Rating	A* - (Very Low Energy)



Light Source

Rated Wattage	12W
Lumens	960
Lumens Per Watt	80
Recommended Product Location	Interior - Stairwell / Office Lighting
Light Source Brand	Epistar LED Chips
Colour Temperature	4000K
CRI Ra	Ra > 80
Lifespan	50,000 Hours
Lamp Working Temperature	<50°C
Beam Angle	110°
Photometric Data	Visit www.saturnled.eu for full Photometric files
Lamp Code	N/A

Electrical

Voltage	220-240V. 50 / 60Hz. AC.
Charge Current (I)	0.08A
Electrical Classification	Class II. (Double Insulated LED Driver). SELV
Cabling Electrical Connections	Screw fix in terminal block
LED Driver	Pri.220-240VAC/Sec:350mA Max DC26V

Installation

Distance from Illuminated Object	0.5m
Method of Fix	Ceiling Recessed
Recommended Working Temperature	Minimum Temp -10°C to Maximum Temp + 40°C
Instruction Sheet	Supplied with product



Origin & Markets

Country of Manufacture	Designed & tested in Europe - Manufactured in China
-------------------------------	---

Intended Market	Europe, Middle East & Australia 220 - 240Volt
------------------------	---

Materials

Main Housing Material	Die Cast Aluminium Powder Coated Body
------------------------------	---------------------------------------

Fixings Main Housing	Steel screws
-----------------------------	--------------

Front Shield	Frosted PC diffuser
---------------------	---------------------

Approvals

Warranty	3 Year Warranty - For more information go to www.saturnled.eu/warranty
-----------------	---

Marks & Symbols	CE -- SELV -- RoHS -- EMC -- WEEE
----------------------------	-----------------------------------

Quality Assurance System	SaturnLED quality assurance to ISO9001:2008
---------------------------------	---

Certificate of Conformity	Available on request - technical@saturnled.eu
----------------------------------	---

Manufactured in Accordance to	British Standard - BS EN 60598 - 2 - 1
--------------------------------------	--



SATURNLED[®]

Simplified

